

BIGTREE TECH



KNOMI

VERSION 2023-04-28

Welcome to KNOMI		Configuring Wi-Fi	2
Performance Comparison Test		Installing KNOMI on StealthBurner	4
Table of Contents		Adding Relevant Macros	10
Packing List		KNOMI UI	11
Overview	1		

Thanks **CHAOTICLAB** for providing guidance on Voron's official style build guide.

WHAT IS KNOMI

KNOMI is a mini round screen designed specifically for Klipper running 3D printers, offering users a unique and personalized way to monitor their printer's operation. The screen displays important information through KNOMI UI, such as heated bed temperature, nozzle temperature, leveling status, printing progress, etc. KNOMI is an open-source product, allowing users to customize the user interface and design mounting brackets to fit their specific 3D printer.

FEATURES

- KNOMI UI-based display for quick and easy monitoring of printer status.
- User-friendly, wireless communication through WiFi.
- Open-source enables effortless customization and adaptation of KNOMI to various 3D printers with provided 3D model files, while also allowing personalized user interfaces to suit preferences.
- Compatibility with Voron StealthBurner using our custom printed part files.
- Wide input voltage range (DC 5V-24V) for convenient power supply.
- Reserved Type-C port for DIY burning, increasing versatility.
- Full-view screen for accurate color representation from any angle.

LINK TO OPEN SOURCE

<https://github.com/bigtreotech/KNOMI>

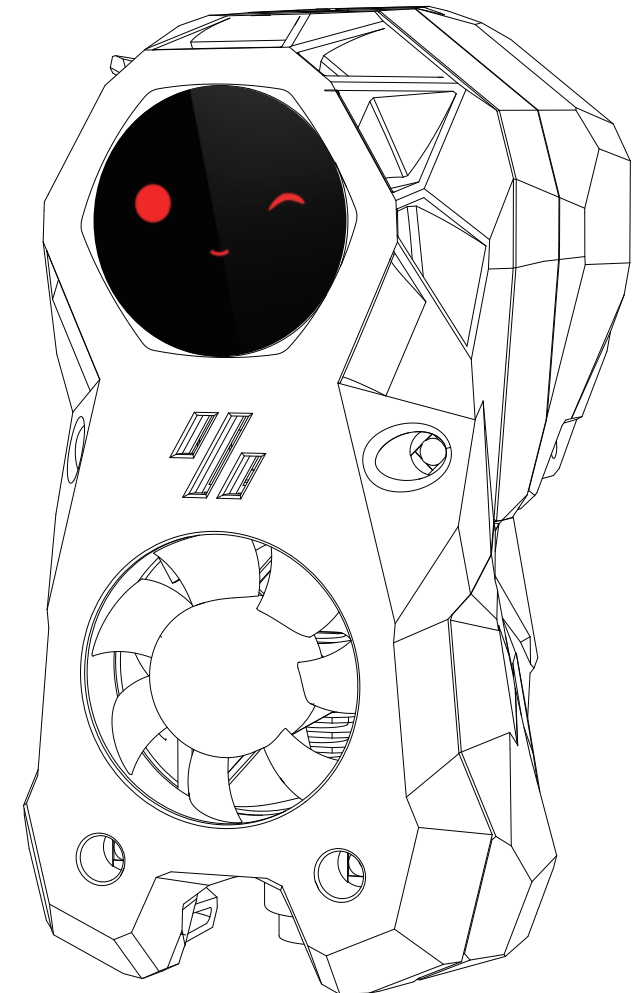

PERFORMANCE COMPARISON TEST

WWW.BIGTREE-TECH.COM

DOES USING KNOMI IMPACT YOUR STEALTHBURNER'S PERFORMANCE?

We will offer the customized mounting printed part files for you to effortlessly install KNOMI into your Voron Stealthburner, in which the StealthBurner main body retains the original fan position and incorporates additional vents on the top for enhanced compatibility and optimized heat dissipation.

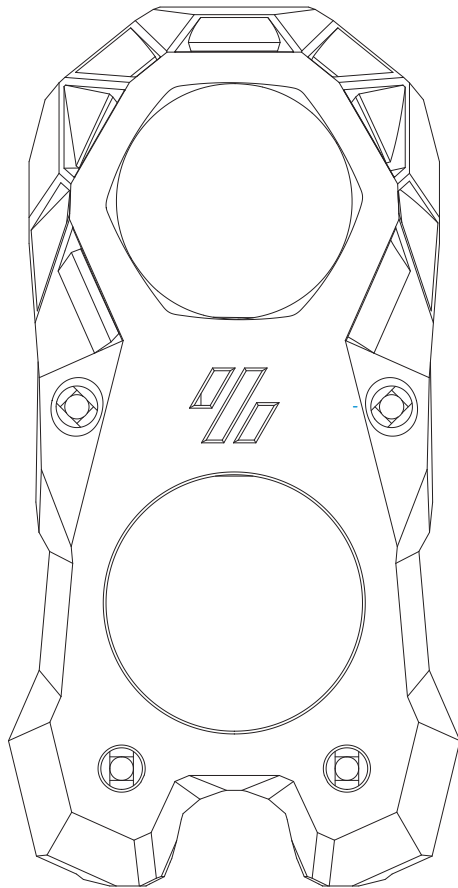

StealthBurner Main Body for KNOMI

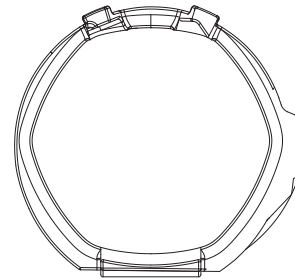

Mounting Plate

DOWNLOAD THE PRINTED PARTS

<https://github.com/bigtreotech/KNOMI>

MOUNTING PLATE

Prior to initiating the installation procedure, it is advised to have these two printed parts readily available. Owing to size limitations and air duct considerations, the Mounting Plate has been engineered with a snap-fit design. This may be prone to damage during repeated disassembly and assembly. It is recommended to print additional backup pieces for convenience.

PERFORMANCE COMPARISON TEST

WWW.BIGTREE-TECH.COM

We conducted a comparative analysis measuring wind speed and acoustic energy levels between the original StealthBurner and our customized version featuring vents and KNOMI add-on. The results showed that both versions performed similarly, indicating that adding KNOMI will not compromise the performance of the StealthBurner.

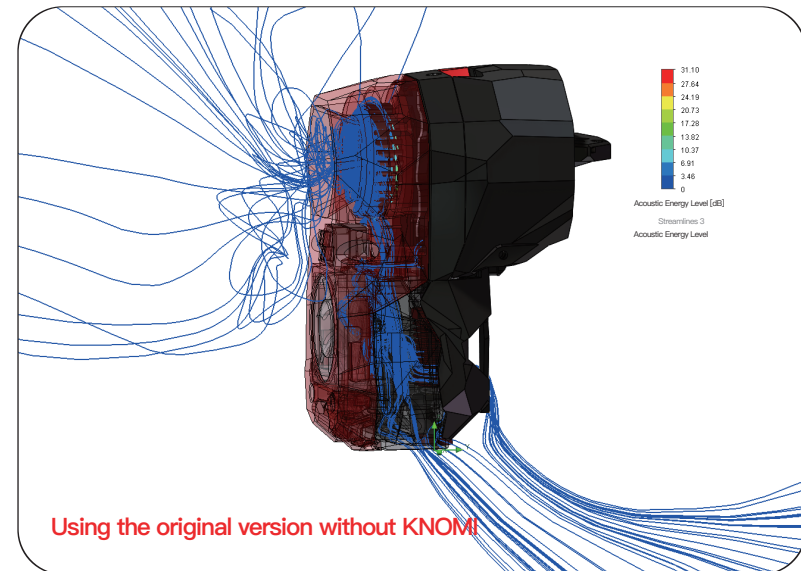
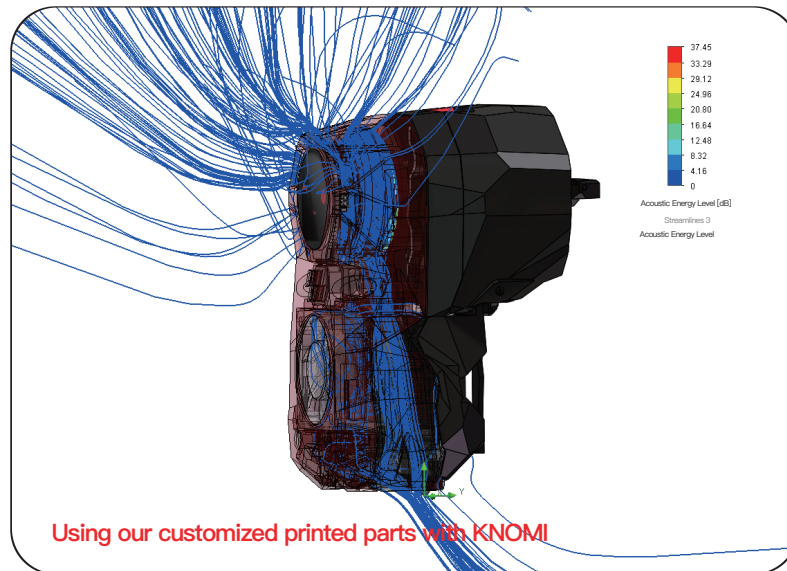
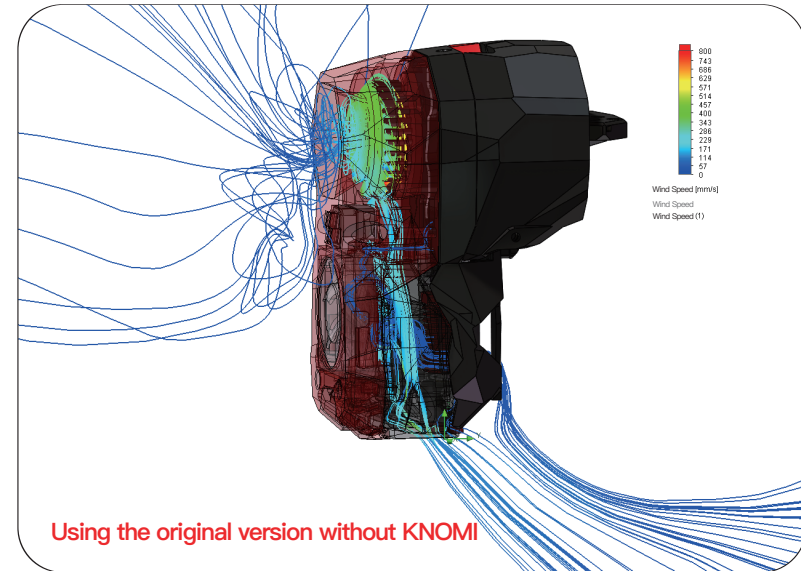
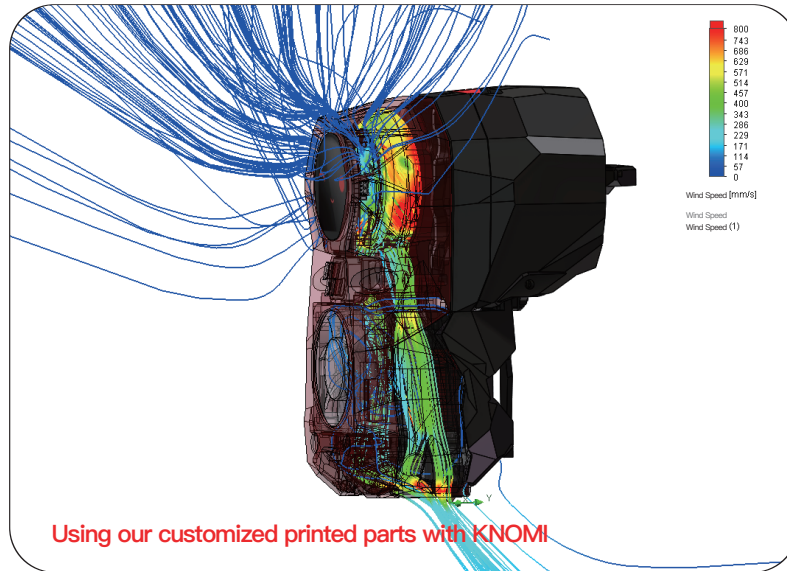

PACKING LIST

WWW.BIGTREE-TECH.COM

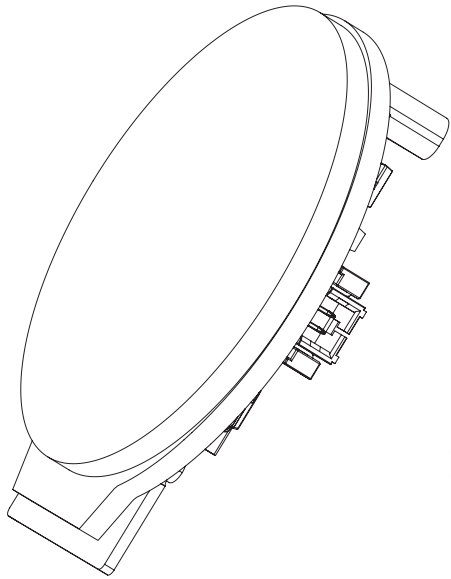

KNOMI

1pc

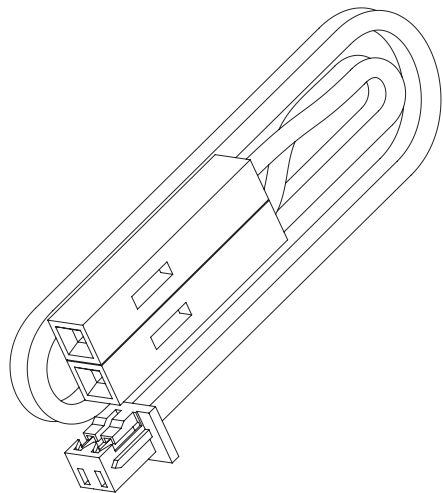

CABLE (MX1.25-2pin to 2x DuPont 2.54-1pin)

1pc

OVERVIEW

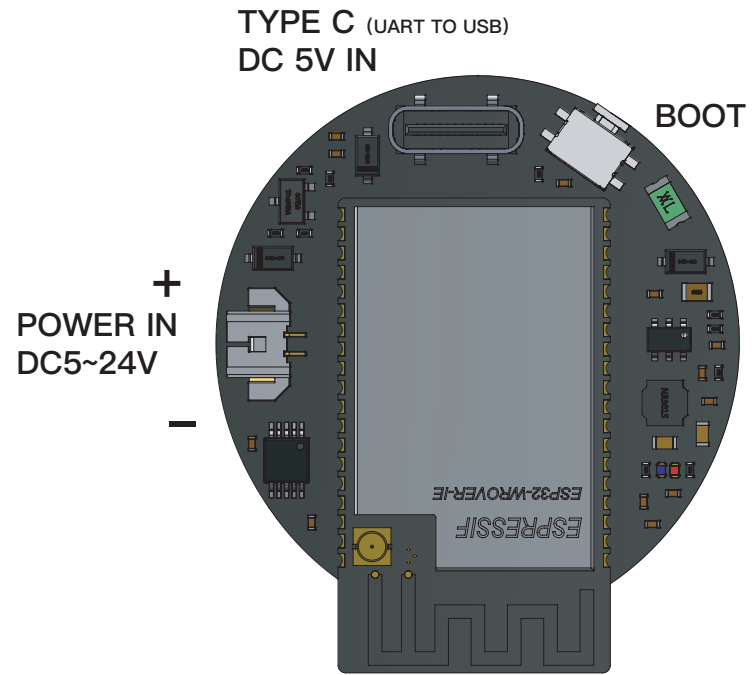
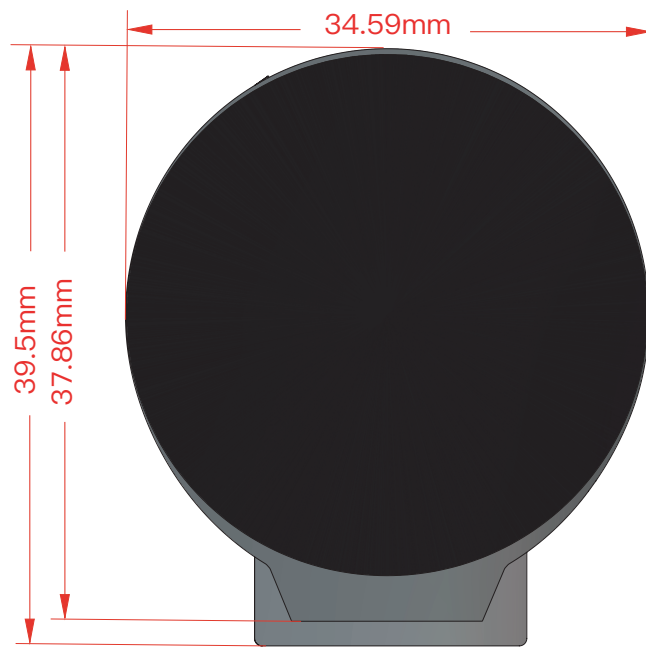

CONFIGURING WIFI



ACTIVATE THE HELLO INTERFACE

Power KNOMI using either the Type-C or MX1.25 interface. While KNOMI is powered on, press and hold the BOOT button for 5 seconds. Wait for KNOMI to display the HELLO message then release the BOOT button.

Alternatively, following the installation's completion, the BOOT button may be pressed using a slender tool, such as a hex key.

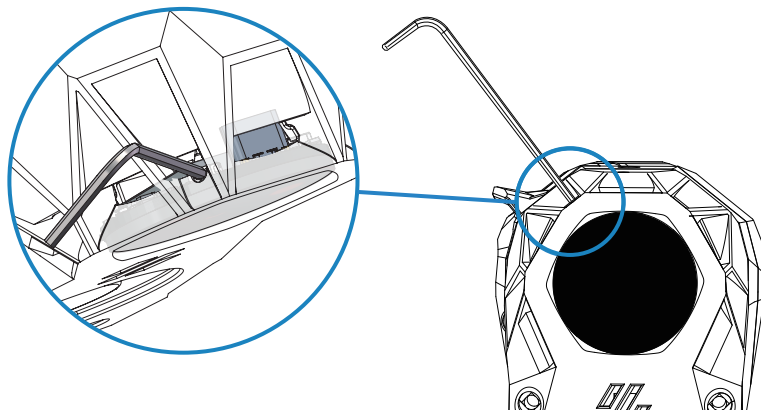

COMPATIBILITY

Due to device compatibility issues, KNOMI cannot configure networks with WPA PSK encryption. If you encounter an error configuring your network with KNOMI, please check the encryption method of your router and switch it to WPA/WPA2 PSK mixed mode or another compatible mode.

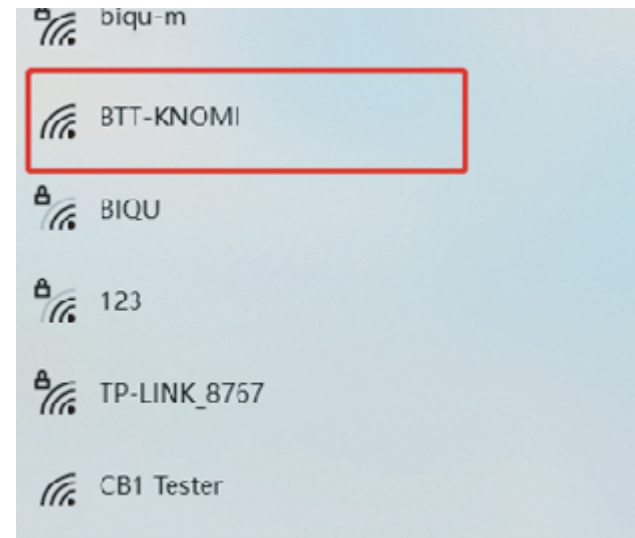

CONNECTING TO KNOMI

1. Using a Wi-Fi-enabled device, locate and connect to the "BTT-KNOMI" network.
2. Allow your browser to automatically open the configuration page.
3. Input your local area network Wi-Fi credentials and the printer IP address in the designated fields.
4. Select "Submit" to save your settings.
5. Upon seeing the submission success page, close the browser.
6. Allow an about 10 seconds for the display screen to transition to the standard work interface following a successful network connection.

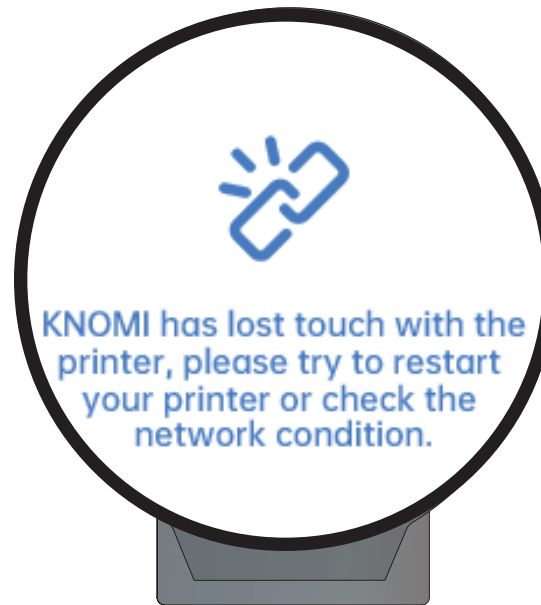

KNOMI DISCONNECTED

If KNOMI is displaying this interface, it means that KNOMI is disconnected from the printer. This may be caused by the following problems:

1. You have modified the Wi-Fi name or password, causing KNOMI and the printer to be in different network states. To resolve this, press and hold the BOOT button on the side of KNOMI for 5 seconds to enter the "HELLO" interface. From there, you can reconfigure the network connection.
2. The printer has a network failure and cannot establish a network connection with KNOMI. To resolve this, try restarting your 3D printer.

INSTALL KNOMI TO STEALTHBURNER

WWW.BIGTREE-TECH.COM

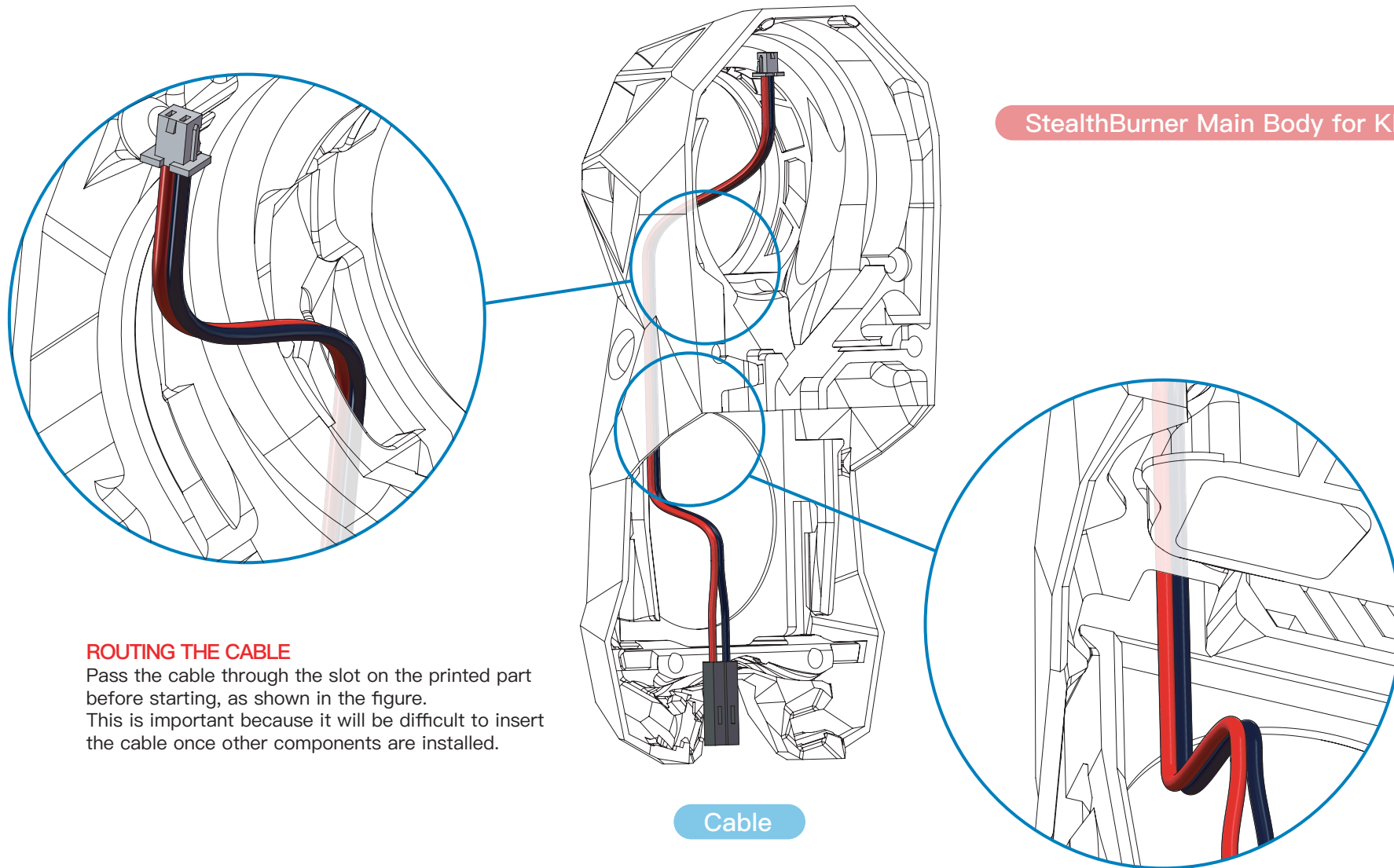

ROUTING THE CABLE

Pass the cable through the slot on the printed part before starting, as shown in the figure. This is important because it will be difficult to insert the cable once other components are installed.

INSTALL KNOMI TO STEALTHBURNER

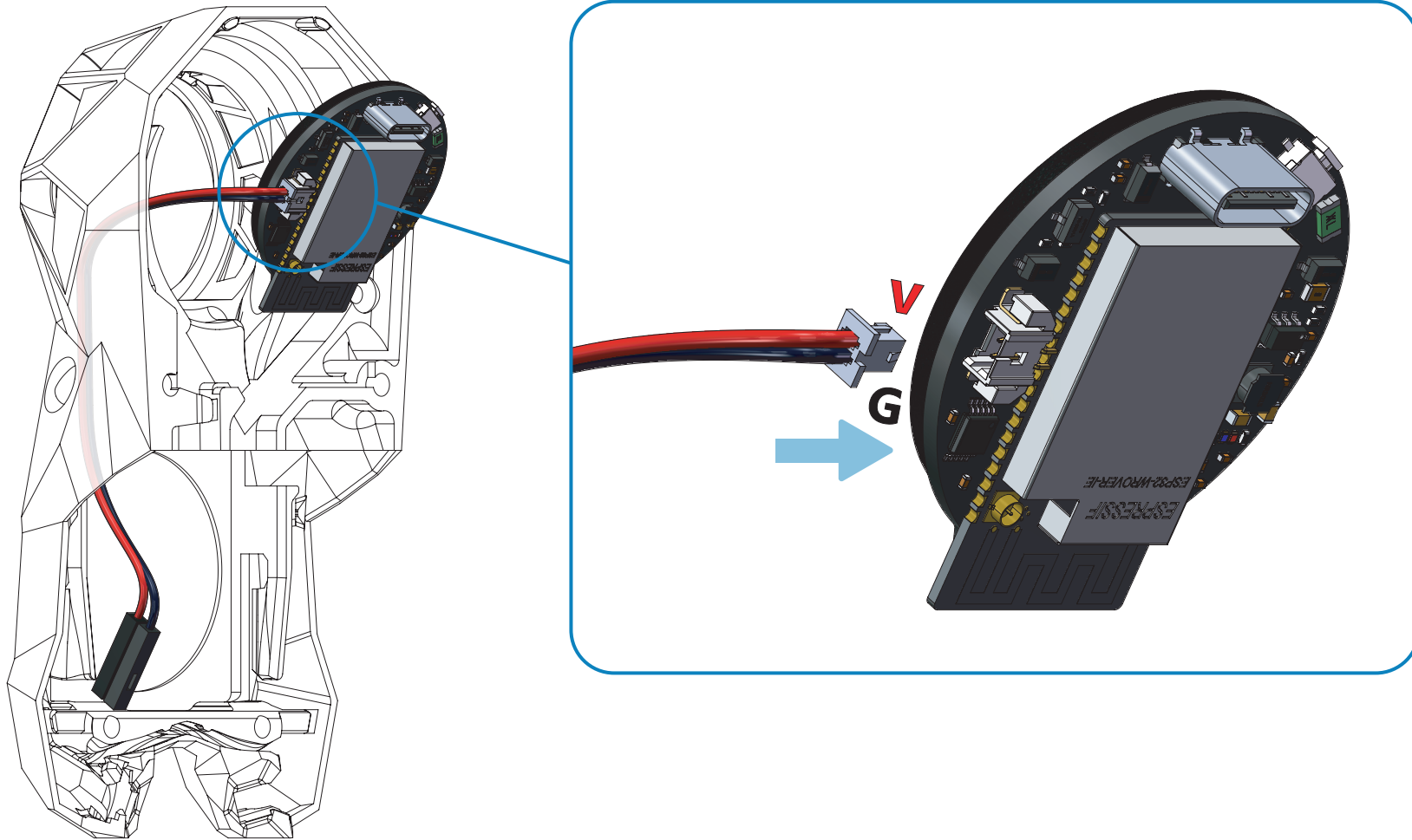

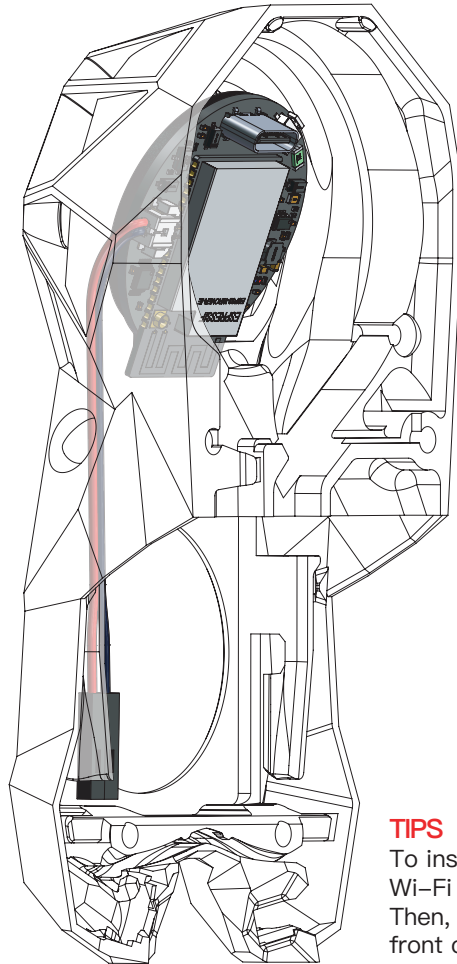

TIPS

To insert the KNOMI, first angle it so that the Wi-Fi antenna side is inserted into the slot. Then, carefully put the entire KNOMI into the front cover printed part until it is flush with the surface.

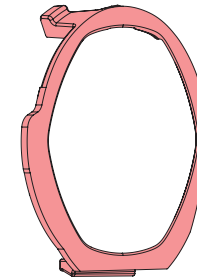
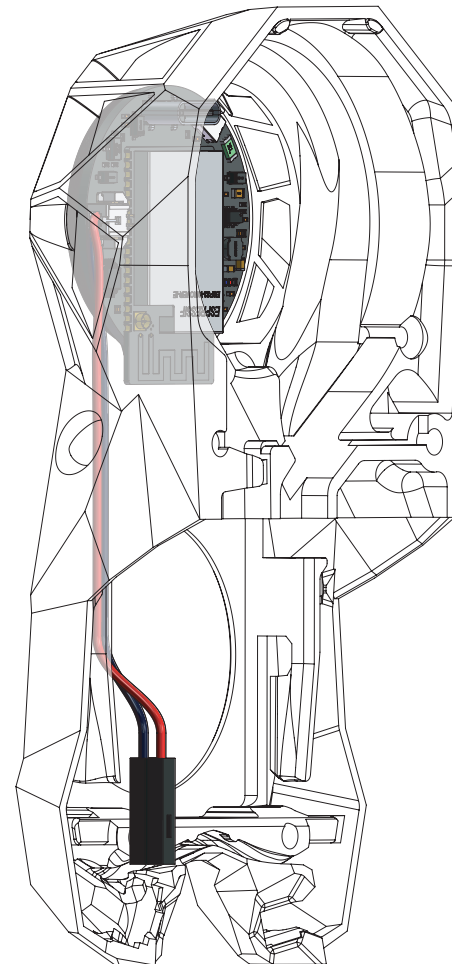

FIX

Use the mounting plate to securely fix KNOMI in place.

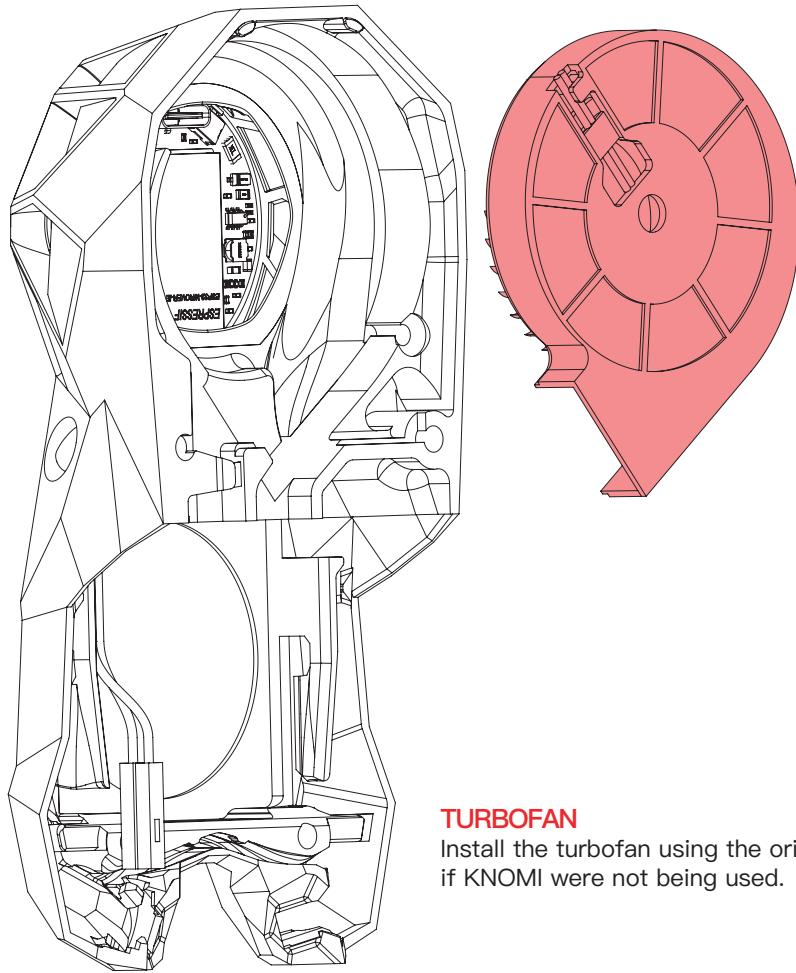

TURBOFAN

Install the turbofan using the original method as if KNOMI were not being used.

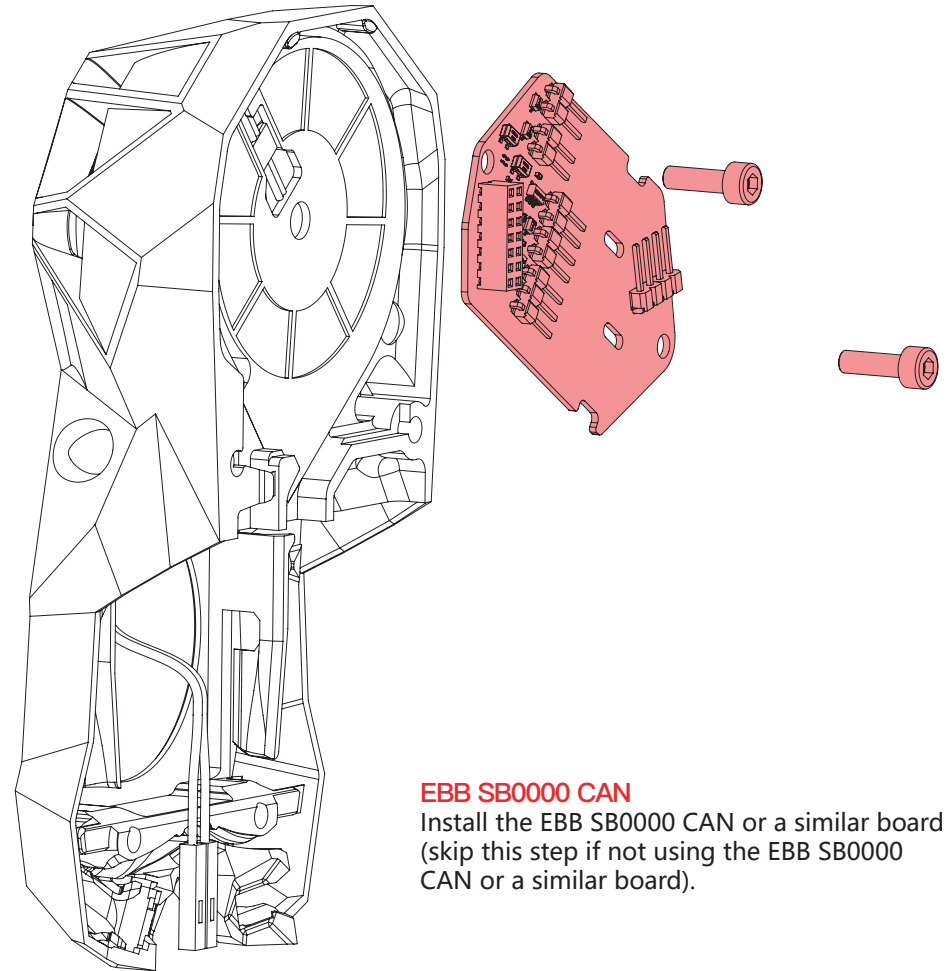

EBB SB0000 CAN

Install the EBB SB0000 CAN or a similar board (skip this step if not using the EBB SB0000 CAN or a similar board).

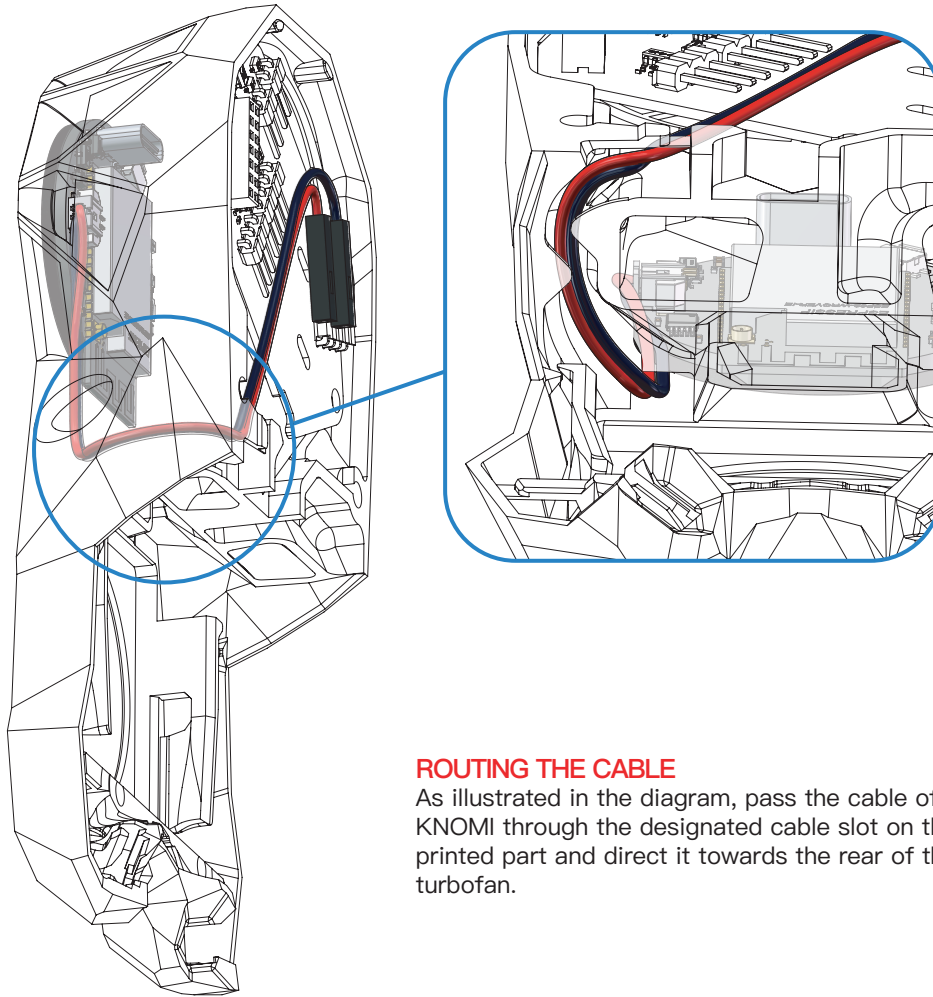

ROUTING THE CABLE

As illustrated in the diagram, pass the cable of KNOMI through the designated cable slot on the printed part and direct it towards the rear of the turbofan.

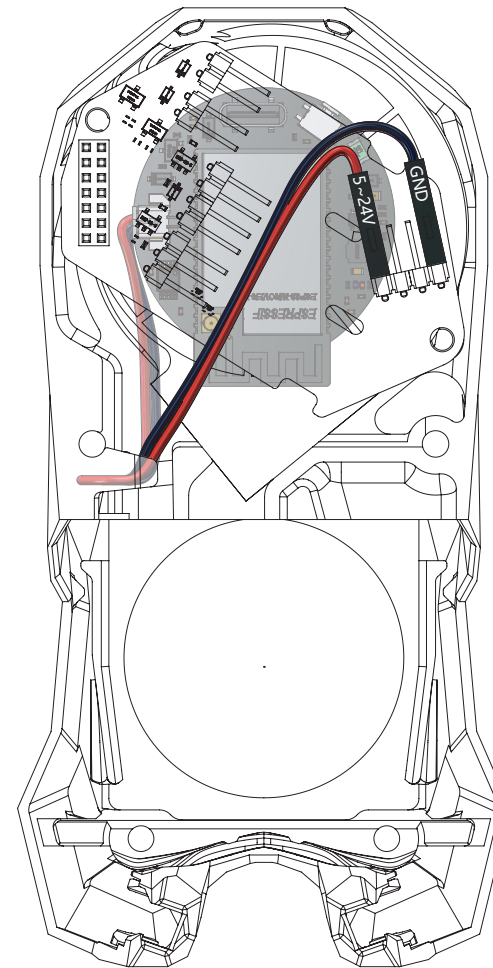

POWER SUPPLY

KNOMI is compatible with a voltage range of 5–24V.

If you are not using an EBB SB 0000 CAN or a similar one, route the cable to the position shown in the provided image, and then connect it to your motherboard or an alternative power source.

TIPS

Proceed with the installation of LEDs, axial fans, and other components following the same steps as if KNOMI were not being used. Prior to powering on the device, inspect for potential short circuits or reverse polarity issues.

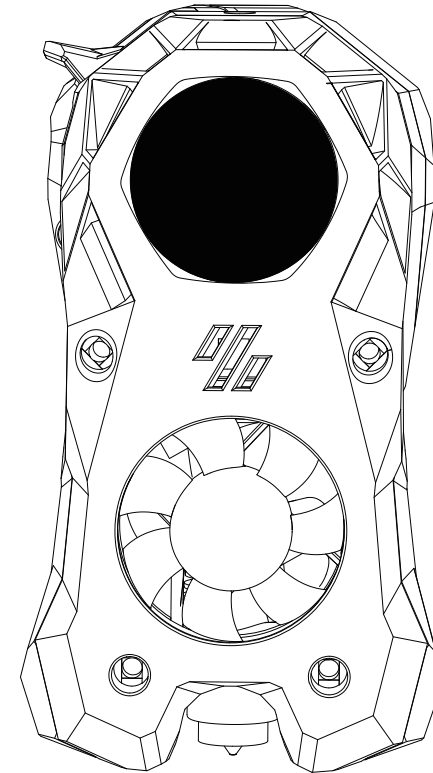

```

printer.cfg *
112 |
113 |
114 | [gcode_macro BED_MESH_CALIBRATE]
115 |   rename_existing: BED_MESH_CALIBRATE_BASE
116 |   variable_probing:False
117 |
118 |   gcode:
119 |     SET_GCODE_VARIABLE MACRO=BED_MESH_CALIBRATE VARIABLE=probing VALUE=True
120 |     BED_MESH_CALIBRATE_BASE
121 |     SET_GCODE_VARIABLE MACRO=BED_MESH_CALIBRATE VARIABLE=probing VALUE=False
122 |
123 | [gcode_macro G28]
124 |   rename_existing: G0028
125 |   variable_homing:False
126 |
127 |   gcode:
128 |     SET_GCODE_VARIABLE MACRO=G28 VARIABLE=homing VALUE=True
129 |     G0028
130 |     SET_GCODE_VARIABLE MACRO=G28 VARIABLE=homing VALUE=False
131 |

```

TIPS
 You can copy it.
 It's not a picture.

HOMING AND LEVELING

KNOMI requires the addition of relevant macros for homing and leveling within the printer.cfg file. Access the print control interface by entering the Klipper IP address into your browser, locate the config Files directory containing printer.cfg, and insert the following macro definitions. Once completed, save and exit.

KNOMI user interface employs visual elements during various stages of printer operation to provide status information to the user:



STANDBY

The printer awaits operational instructions.

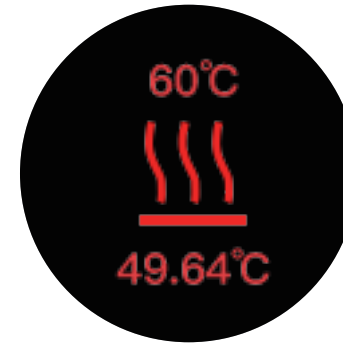

HEATED BED – HEATING

The target temperature is indicated at the top, while the real-time progress of the temperature change is shown at the bottom.

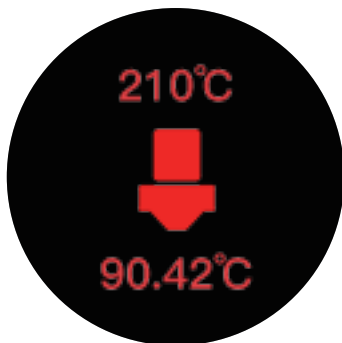

NOZZLE – HEATING

The target temperature is indicated at the top, while the real-time progress of the temperature change is shown at the bottom.

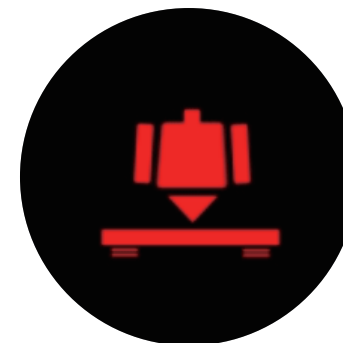

LEVELING

The printer is leveling.



READY TO PRINT

The bed and nozzle have reached their respective target temperatures, and the printer is ready to print.



START PRINTING

The printhead is in motion and starts to print.



PRINTING PROGRESS

After 1% progress, KNOMI will display this UI.



Print Completed

The print has been completed.

Website

WWW.bigtree-tech.com

GitHub

WWW.github.com/bigtreotech

Discord

www.discord.gg/5jdwbyYZuv

